

**Industrial 2.5inch SATAⅢ SSD  
A-Series 3D TLC  
with Power shield  
256GB~2TB**

**データシート**

**Features**

- Compliance with
  - Industrial Standard SATA Revision 3.1 compliant
  - Industrial Standard ATA/ATAPI-8 and ACS-3 command compliant
  - Supports SATA interface rate of 6Gb/s (backward compatible to 1.5Gb/s and 3Gb/s)
  - Native Command Queuing up to 32 commands
  - Supports SATA device sleep mode(DevSleep)
  - Supports Garbage Collection
  - Self-Monitoring, Analysis, and Reporting Technology(S.M.A.R.T)
  - Supports 28-bit and 48-bit LBA(Logical Block Addressing) mode commands
  
- Capacities
 

**Bics5:**

  - 3D TLC: 256GB, 512GB, 1TB, 2TB
  
- Data Protection and Reliability
  - Excellent Power Shield function, when a suddenly power failure can protect the integrity of the data write.
  - Supports data quick erase
  - Hardware LDPC ECC engine with hard-decision and soft-decision decoding
  - RAID engine offers additional level of data protection
  - Internal data shaping technique increased data endurance
  - Early weak block retirement option
  - Global wear leveling algorithm evens program/erase count and extends SSD lifespan
  - Supports DDR3/DDR3L

- MTBF
  - 2,000,000 hours
  
- Temperature ranges
  - Operating:
    - Standard: 0°C to 70°C
    - Industrial: -40°C to 85°C
  - Storage:
    - 55°C to 95°C
  
- Supply voltage
  - 5V ±5%
  
- Form factor
  - 2.5 inch
  
- Shock & Vibration
  - Shock: 1500G@0.5ms
  - Vibration: 20 G
  
- Certification and Compliance
  - FCC
  - CE
  - RoHs
  
- NAND Flash Type
  - 3D TLC

## TABLE OF CONTENTS

1. Product Description .....	5
1.1. Introduction.....	5
1.2. Block Diagram .....	5
2. Product Specifications .....	6
2.1. Capacity .....	6
2.2. Performance.....	6
2.3. Software Function .....	6
2.4. Power shield function.....	7
3. Reliability Specifications.....	8
3.1. Environmental Conditions .....	8
3.2. TBW.....	8
4. Specification.....	9
4.1. Overlook.....	9
4.2. Dimension.....	9
4.3. Electronic Specifications.....	10
4.4. Error Detection and Correction.....	13
4.5. Wear-Leveling.....	13
4.6. Bad Blocks Management.....	13
4.7. Mean Time Between Failures (MTBF).....	13
4.8. Endurance .....	14
4.9. Transfer Mode.....	14
4.10. Power Characteristics .....	14
5. Installation Requirements.....	15
5.1. Electrical Connections for 2.5 SSD.....	15
5.2. Device drive.....	15

## Revision History

Rev	Date	Description
1.0	2022/10/25	First Release

# 1. Product Description

## 1.1. Introduction

This SSD is a high-performance SATA 6Gb/s SSD ideally suited for client SSDs, Ultrabook's, and Tablets. This SSD fully supports high-speed Toggle, ONFI, as well as the latest generation NAND flash, enabling the realization of fast, reliable, and feature-wise SSDs on the market. This SSD provides comprehensive data protection and enhances the endurance and retention of TLC NAND, achieving longer durability for SSD.

Another innovative design feature is worth mention is "Power Shield" , excellent electronic circuit design provides high efficiency power protection capacitor charging efficiency, when a suddenly power failure can protect the integrity of the data write.This SSD is the perfect storage device for industrial PCs, Vehicle System, Professional-Grade Photography System.

## 1.2. Block Diagram

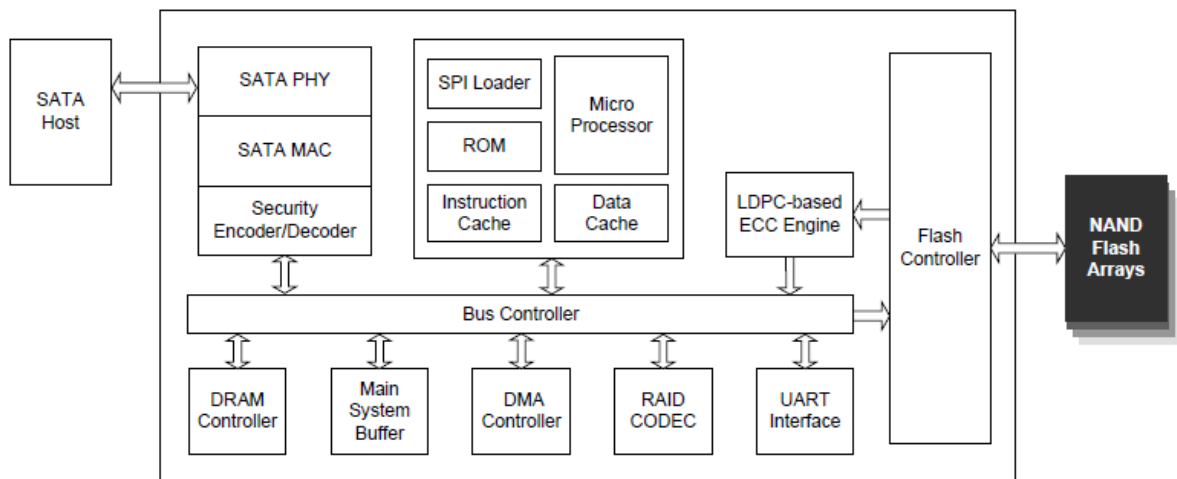

## 2. Product Specifications

### 2.1. Capacity

Raw Capacity	Capacity	LBA
256GB	224GB	468,862,128
512GB	447GB	937,703,088
1 TB	894GB	1,875,385,008
2 TB	1789GB	3,750,748,848

Notes:

This data is for reference.

### 2.2. Performance

#### ■ 3D TLC (Bics5)

Capacity	256GB	512GB	1TB	2TB
Sequential Read(Max)	450 MB/sec	510 MB/sec	555 MB/sec	550 MB/sec
Sequential Write(Max)	300 MB/sec	431 MB/sec	397 MB/sec	419 MB/sec

Notes:

1. Performance may base on SSD capacity, hardware test platform, test software, operating system and other system variables.

2. The performance provided is the highest of the same capacity combinations.

The actual speed will be different because the ICs and channels are different from the quantity.

### 2.3. Software Function

- ECC Scheme
- UART function
- GPIO
- S.M.A.R.T
- TRIM
- AES

## 2.4. Power shield function

Excellent Power Shield function, when a suddenly power failure can protect the integrity of the data write.

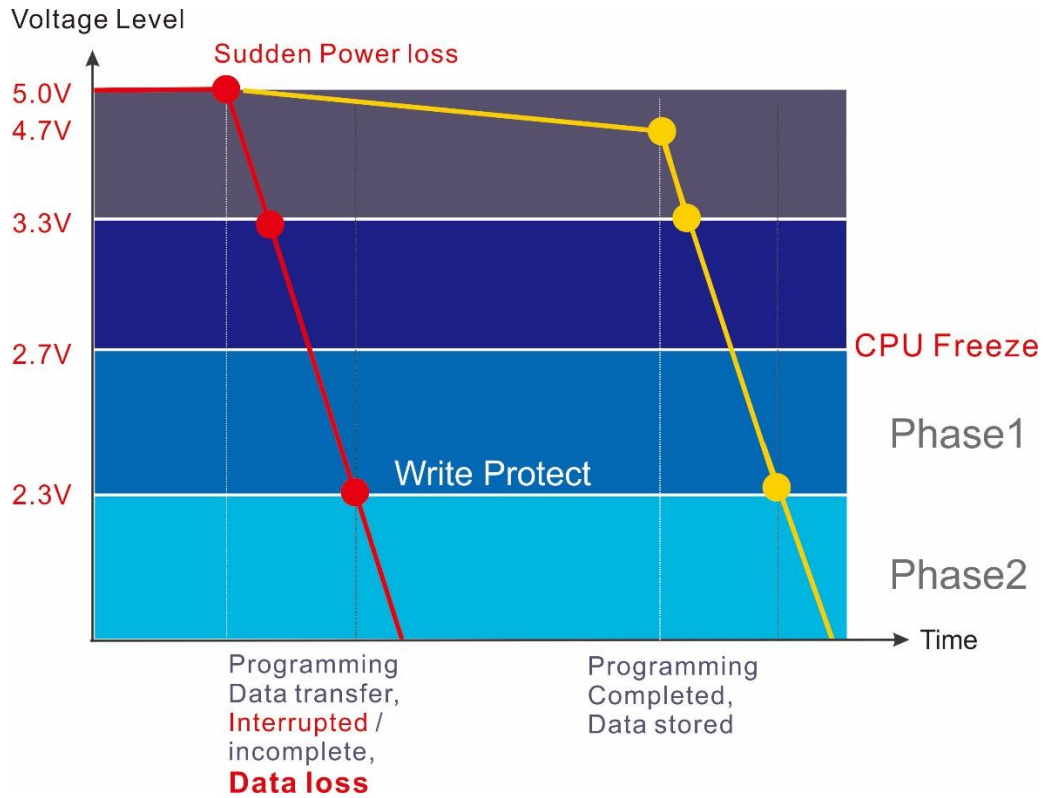

### 3. Reliability Specifications

#### 3.1. Environmental Conditions

Environmental specifications are following MIL-STD-810F, as following table.

Environment	Specification
Storage Temperature	-55°C ~ +95°C
Operating Temperature	0°C to 70°C (Standard) ; -40°C to 85°C (Industrial)
Vibration	20G(7~2K Hz, 3 axes)
Shock	1500G@0.5ms
Humidity	Relative Humidity: 10-95%, non-condensing
MTBF	>2,000,000 hours

Note1: Vibration reference standard "IEC 60068-2-6"

Note2: Shock reference standard "IEC 60068-2-27"

Note3: MTBF condition," Telcordia SR-332"

#### 3.2. TBW

Capacity	TBW
TLC 256GB	385TB
TLC 512GB	769TB
TLC 1TB	1538TB
TLC 2TB	3077TB



## 4. Specification

### 4.1. Overview

The overlook views of 2.5 SSD are illustrated in Figure 1.



Figure 1: 2.5 SSD Overlook Diagram

### 4.2. Dimension

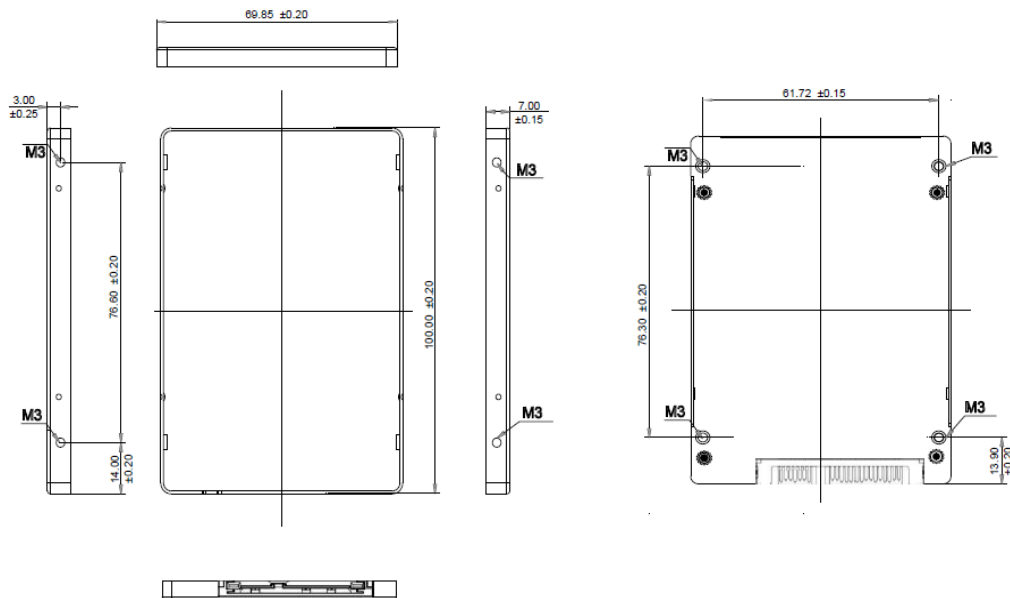

Form Factor	Width (mm)	Length(mm)	Height (mm)
SATA III	69.85 ±0.15mm	100 ±0.15mm	7 ±0.15mm

### 4.3. Electronic Specifications

#### 4.3.1 Pin Signal Assignment

The signals assigned for Serial ATA applications are described in Table 1

Group	Pin No.	Function	Description
Signal Segment	S1	GND	Ground
	S2	RX+	Differential signal pair A
	S3	RX-	
	S4	GND	Ground
	S5	TX-	Differential signal pair B
	S6	TX+	
	S7	GND	Ground
Key & Spacing			
Power Segment	P1	NC	No connect on the device side
	P2	NC	No connect on the device side
	P3	DEVSLP	Device Sleep Pin
	P4	GND	Ground
	P5	GND	Ground
	P6	GND	Ground
	P7	V5	5V power input
	P8	V5	5V power input
	P9	V5	5V power input
	P10	GND	DAS/DSS
	P11	DAS/DSS	Device Activity Signal / Decision Support Systems
	P12	GND	Ground
	P13	NC	No connect on the device side
	P14	NC	No connect on the device side
	P15	NC	No connect on the device side

Table 1 –2.5" SATA SSD connector pin definition

### 4.3.2 Support ATA Commands

ATA Command Set summarizes the ATA command set with the paragraphs that follow describing the individual commands and the task file for each.

Command	Code	Protocol
<b>General Feature Set</b>		
Execute Drive Diagnostic	90h	Device diagnostic
Flush Cache	E7h	Non-data
Identify Device	ECh	PIO data-in
Initialize Drive Parameters	91h	Non-data
Read DMA	C8h	DMA
Read Log Ext	2Fh	PIO data-in
Read Multiple	C4h	PIO data-in
Read Sector(s)	20h	PIO data-in
Read Verify Sector(s)	40h or 41h	Non-data
Set Feature	EFh	Non-data
Set Multiple Mode	C6h	Non-data
Write DMA	CAh	DMA
Write Multiple	C5h	PIO data-out
Write Sector(s)	30h	PIO data-out
NOP	00h	Non-data
Read Buffer	E4h	PIO data-in
Write Buffer	E8h	PIO data-out
<b>Power Management Feature Set</b>		
Check Power Mode	E5h or 98h	Non-data
Idle	E3h or 97h	Non-data
Idle Immediate	E1h or 95h	Non-data
Sleep	E6h or 99h	Non-data
Standby	E2h or 96h	Non-data
Standby Immediate	E0h or 94h	Non-data
<b>Security Mode Feature Set</b>		
Security Set Password	F1h	PIO data-out
Security Unlock	F2h	PIO data-out
Security Erase Prepare	F3h	Non-data
Security Erase Unit	F4h	PIO data-out
Security Freeze Lock	F5h	Non-data
Security Disable Password	F6h	PIO data-out

Command	Code	Protocol
<b>SMART Feature Set</b>		
SMART Disable Operations	B0h	Non-data
SMART Enable/Disable Autosave	B0h	Non-data
SMART Enable Operations	B0h	Non-data
SMART Execute OFF-LINE Immediate	B0h	Non-data
SMART Read Data	B0h	PIO data-in
SMART Read Threshold	B0h	PIO data-in
SMART Return Status	B0h	Non-data
SMART Save Attribute Values	B0h	Non-data
<b>Host Protected Area Feature Set</b>		
Read Native Max Address	F8h	Non-data
Set Max Address	F9h	Non-data
Set Max Set Password	F9h	PIO data-out
Set Max Lock	F9h	Non-data
Set Max Freeze Lock	F9h	Non-data
Set Max Unlock	F9h	PIO data-out
<b>48-bit Address Feature Set</b>		
Flush Cache Ext	EAh	Non-data
Read Sector(s) Ext	24h	PIO data-in
Read DMA Ext	25h	DMA
Read Multiple Ext	29h	PIO data-in
Read Native Max Address Ext	27h	Non-data
Read Verify Sector(s) Ext	42h	Non-data
Set Max Address Ext	37h	Non-data
Write DMA Ext	35h	DMA
Write Multiple Ext	39h	PIO data-out
Write Sector(s) Ext	34h	PIO data-out
<b>NCQ Feature Set</b>		
Read FPDMA Queued	60h	DMA Queued
Write FPDMA Queued	61h	DMA Queued
<b>Others</b>		
Data Set Management	06h	DMA
Seek	70h	Non-data

Table 2: ATA Command List

#### 4.4. Error Detection and Correction

The LDPC ECC engine executes parity generation and error detection/correction features, and enhances decoding throughput and data reliability. With LDPC of correction capability  $1e-2$  RBER, the hard and soft decoding mechanism provides powerful error correction. Hence the SSD can enhance the endurance and retention of TLC NAND and extends the SSD lifespan.

#### 4.5. Wear-Leveling

Flash memory can be erased within a limited number of times. This number is called the erase cycle limit or write endurance limit and is defined by the flash array vendor. The erase cycle limit applies to each individual erase block in the flash device.

#### 4.6. Bad Blocks Management

Bad Blocks are blocks that contain one or more invalid bits whose reliability are not guaranteed. The Bad Blocks may be presented while the SSD is shipped, or may generate during the life time of the SSD. When the Bad Blocks is detected, it will be flagged, and not be used anymore. The SSD implement Bad Blocks management and replacement, Error Correct Code to avoid data error occurred. The functions will be enabled automatically to transfer data from Bad Blocks to spare blocks, and correct error bit. After the reserved block less than 10 of each channel, the SSD will be locked, and cannot be read and written anymore. Host can send a vendor ATA command to unlock the SSD for backup data or system from SSD.

#### 4.7. Mean Time Between Failures (MTBF)

**Failure Rate:** The total number of failures within an item population, divided by the total number of life units expended by that population, during a particular measurement interval under stated condition.

**Mean Time Between Failures (MTBF):** A basic measure of reliability for repairable items: The mean number of life units during which all parts of the item perform within their specified limits, during a particular measurement interval under stated conditions.

Product	Condition	MTBF (Hours)
2.5 SSD	Telcordia SR-332 GB, 25°C	>2,000,000

Table3: 2.5 SSD MTBF

## 4.8. Endurance

- Flash Endurance:
  - 3D TLC: 3,000 P/E Cycle
- Wear-Leveling Algorithm: Support.
- Bad Blocks Management: Support.
- Error Correct Code: Support.

## 4.9. Transfer Mode

- SSD support following transfer mode:
  - Serial ATA I 1.5Gbps
  - Serial ATA II 3.0Gbps
  - Serial ATA III 6.0Gbps

## 4.10. Power Characteristics

### 4.10.1 Supply Voltage

Parameter Specifications	Parameter Specifications
Input Voltage	5V +/- 5%

### 4.11.2 Power Consumption

Parameter Specifications	Specifications (W)
Idle (max.)	0.415W
Active (max.)	2.362W

Notes:

1. The measured power voltage is 5V.
2. Its average value of power consumption is achieved based on 100% conversion efficiency.
3. Power Consumption may differ according to flash configuration and platform.

## 5. Installation Requirements

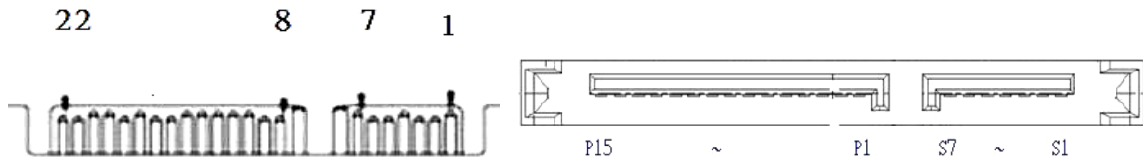

Figure 4: 2.5" SATA SSD Connector Pin Assignment

### 5.1. Electrical Connections for 2.5 SSD

A Serial ATA device may be either directly connected to a host or connected to a host through a cable. For connection via cable, the cable should be no longer than 1 meter. The SATA interface has a separate connector for the power supply. Please refer to the pin description for further details.

### 5.2. Device drive

No additional device drives are required. The 2.5 SSD can be configured as a boot device.